

---

# USER GUIDE



Soundcraft

200 **DELTA**

---



# Contents

<b>Introduction</b>	
Introducing the 200 Delta	2
Precautions and safety instructions	3
Connections	4
Installation	6
Module block diagrams	10
Dimensions	11
Configurations	12
<b>Module descriptions, specifications and operation</b>	
Standard input	14
Deluxe input	16
Dual line input	18
Stereo input	20
Group output	22
Master output	24
Delta Specification	26
<b>Warranty</b>	<b>27</b>
<b>Glossary</b>	<b>28</b>

# Introduction



## Introducing the 200 Delta

The 200 Delta series comprises a range of input module, output module and frame options that lets you configure the console for a wide variety of applications. The only constraint on the selection and positioning of modules is that any console must have a master module (2 channels width) which must be fitted at the right hand side of the console, and that any group output modules fitted have to be positioned immediately to the left of this.

**▲ Should you wish to replace or add extra modules, please contact your authorised Soundcraft dealer, who can supply the modules and change the configuration without voiding warranty.**

The system has four group mixing buses, allowing the inclusion of up to four group output modules, together with the main stereo mix bus, which gives the L+R outputs from the master section. Six Auxiliary send buses are provided, giving six independent outputs with master level controls. The master section also contains a monitor switcher which lets you monitor the desk output, an external (stereo) 2-Track return, or a Pre Fade Listen (solo) signal accessing all inputs and groups.

## Precautions and safety instructions

### General precautions

Avoid storing or using the mixing console in conditions of excessive heat or cold, or in positions where it is likely to be subject to vibration, dust or moisture. Do not use any liquids to clean the fascia of the unit: a soft dry brush is ideal. Use only water or ethyl alcohol to clean the trim and scribble strips. Other solvents may cause damage to paint or plastic parts.

Avoid using the console close to strong sources of electromagnetic radiation (e.g. video monitors, high power electric cabling): this may cause degradation of the audio quality due to induced voltages in connecting leads and chassis. For the same reason, always site the console power supply away from the unit.

In all cases, refer servicing to qualified personnel.

### Handling and transport

The console is supplied in a rugged cardboard box. If it is necessary to move it any distance after installation it is recommended that this packing is used to protect it. Be sure to disconnect all cabling before moving. If the console is to be regularly moved (e.g. for touring) we recommend that it is installed in a foam lined flight case. At all times avoid applying excessive force to any knobs, switches or connectors.

### Power supplies and cabling

**△ Always make sure that the power supply has been set to the same source voltage as the mains supply.**

Consoles with up to 28 channel slots (up to 24 input) are powered by the Soundcraft CPS150 PSU, and are fitted with a 5 way SRC DC power input connector.

Consoles with 36 channel slots (32 input), and 24 input consoles with 16 or more stereo inputs are powered by the Soundcraft CPS450 PSU, and are fitted with a 10 way SRC DC power input connector.

Always use the power supply and power cable supplied with the mixer: the use of alternative supplies may cause damage and voids the warranty; the extension of power cables may result in malfunction of the mixing console.

**△ Always switch the power supply off before connecting or disconnecting the console power cable, removing or installing modules, and servicing. In the event of an electrical storm, or large mains voltage fluctuations, immediately switch off the PSU and unplug from the mains.**

# Connections

## Wiring conventions

The standard 200 Delta console uses two different types of audio connector, 3 pin XLR (diagram 1) and 1/4" three pole (A gauge or stereo) jacks. The latter are used in two different configurations, see diagrams 2 and 3. The rear frame of the console has standard apertures fitted with blanking panels. Your Soundcraft dealer can supply a variety of mounting plates to fit these, with EDAC (ELCO) multiway connectors, together with looms to link them to the modules. Refer to options list on page 26 for details and part numbers.

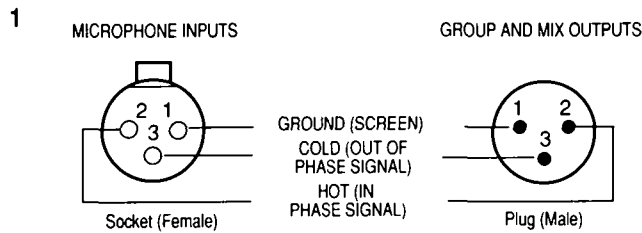

**2a** 1/4" Stereo Jack Plug used as balanced input: line inputs and tape returns

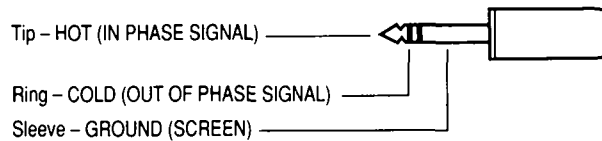

**2b** 1/4" Stereo Jack Plug used as ground compensated or unbalanced output: direct outputs, auxiliary send outputs and control room monitor outputs

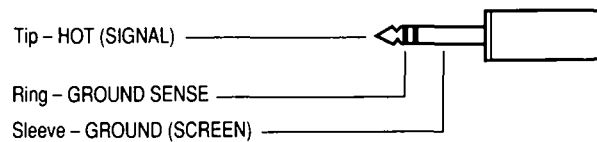

**3** 1/4" Stereo Jack Plug used as insert send/return

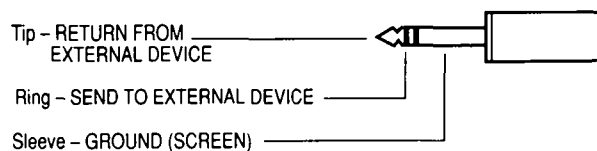

## Connections

### Signal levels

It is important to supply the correct input levels to the console, otherwise signal-to-noise ratio or distortion performance may be degraded; and in extreme cases damage to the internal circuitry may result. Likewise, on all balanced inputs avoid sources with large common mode DC, AC or RF voltages, as these will reduce the available signal range on the inputs. Note that 0dBu = 0.775V RMS.

The microphone input is designed for use with balanced low impedance (150 or 200 ohm) microphones.

**⚠ DO NOT use unbalanced microphones or battery powered condenser microphones with the +48V phantom power switched on: degraded performance or damage to the microphone may result.**

The sensitivity of the microphone input is variable from -2dBu to -70dBu (for +4dBu at the Stereo Mix outputs), and the maximum input level (balanced) is 20dB above the set sensitivity—that is, with the gain control at minimum, the maximum input level is +18dBu. Although the microphone input can thus handle some line level signals, we don't recommend this, since the source may be unduly loaded by the low (2Kohm) input impedance, or be damaged by the +48V phantom power.

The line input has a sensitivity variable between -20dBu and +10dBu, and can also handle a maximum input level up to 20dB above the set value. Note that the maximum input level for unbalanced inputs is 4 or 5 dB less than that for balanced signals, so very high level unbalanced signals (e.g. loudspeaker outputs of power amplifiers) may cause distortion. The input impedance is approximately 20Kohms, and thus high impedance sources (e.g. electric guitars) may be loaded too heavily. Such sources are best fed through an external DI (Direct Inject) box to the microphone input.

The main outputs of the console (e.g. Stereo mix, group outputs, aux sends) have a nominal output level of +4dBu, and an impedance of 75ohms. The Stereo mix and Group outputs also have the facility to switch the operating level to -10dBV to allow easy interface to domestic and semi professional equipment. These outputs will deliver full level (+21dBu unbalanced, +27dBu balanced) into loads of greater than 600ohms. Secondary outputs, such as channel insert sends and channel direct outputs (all unbalanced) have a nominal output level of -2dBu and a slightly higher output impedance of 200ohms, and will only deliver the full output level of +21dBu into load impedances of greater than 5Kohms.

## Installation

### Examples of use

The diagrams opposite and overleaf show typical applications of a 16 input 200 Delta in PA, recording and keyboard mixing situations. Such examples are of course only an indication of possible systems, the exact setup being determined by your own system requirements and the configuration of the console.



Use as the front-of-house console in a sound reinforcement system. Microphones covering drums, guitars, vocals and a DI box for the bass guitar are fed to mic inputs 1 to 12. Stereo input modules are fitted to positions 13 to 16, and receive the outputs from an on-stage keyboard mixer and three stereo effects devices. The output from AUX 1 and AUX 2 feed power amplifiers to provide on-stage monitoring, whereas the outputs from AUX 3 through AUX 5 feed effects processors. The stereo mix outputs feed the main power amplifiers for the house speaker system.

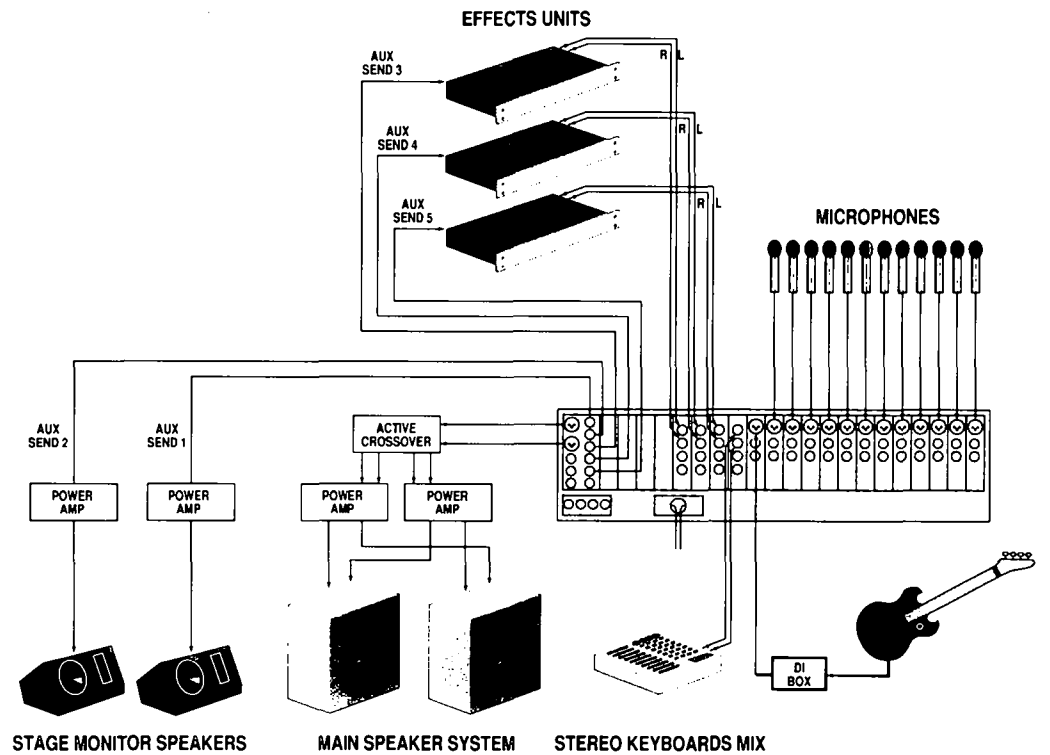

## Eight Track Recording

Mixer in an eight-track recording system. Microphones and line sources (keyboards, Direct Injected instruments, etc) are fed to the input channels, which are routed to group outputs 1...4 as required. The group outputs feed tracks 1 to 4 and 5 to 8 in parallel, and the outputs from the multitrack machine are monitored through the returns on the groups. The stereo mix outputs feed the 2-track mastering recorder, which can be monitored through the 2-track return. AUX 1 feeds an amplifier driving artistes headphones, whilst AUX 3 to 6 are used as effects sends.

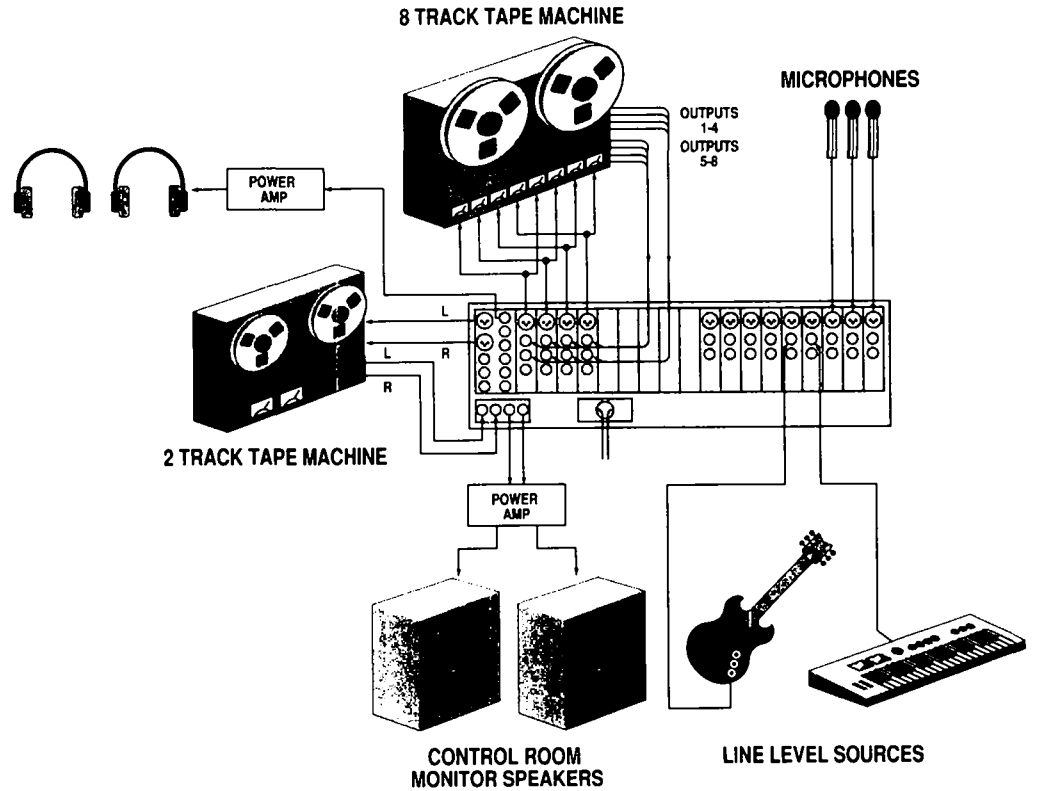

On-stage rack mounting keyboard mixer. Two synthesisers, two expanders, a sampler, a foldback send from the main PA and two stereo effects processors are connected to the inputs. AUX 3 and AUX 4 outputs feed the inputs of the effects devices. The stereo MIX outputs are fed to the front of house console, the control room outputs feeding the local monitor amplifiers.

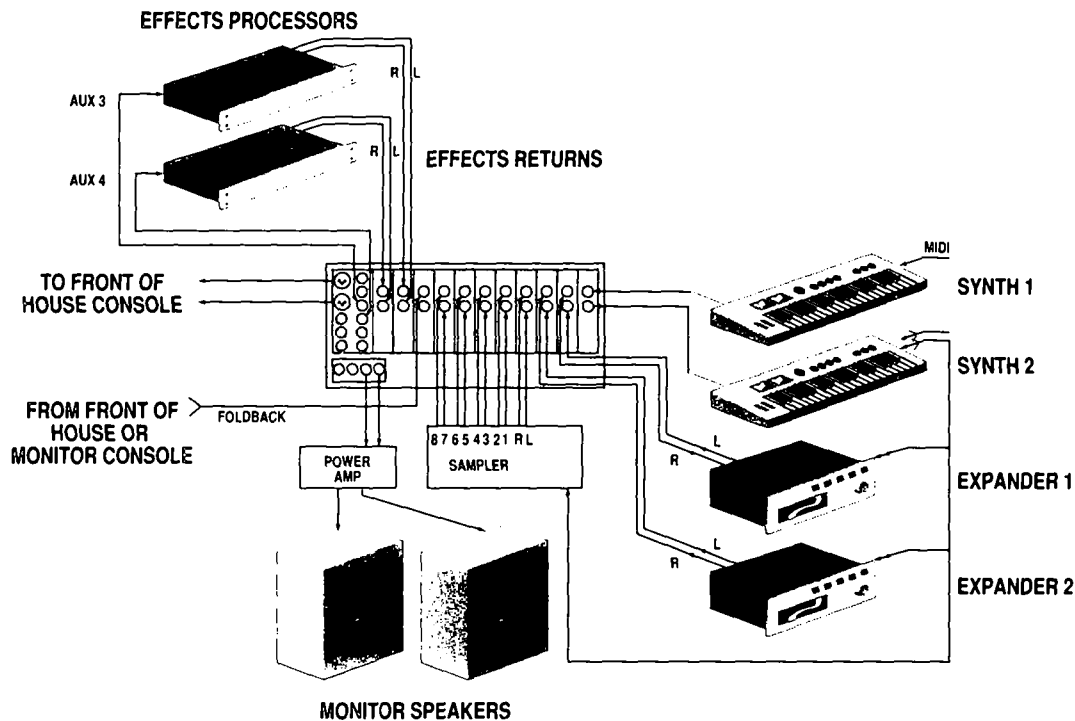

# Module block diagrams

## STANDARD INPUT

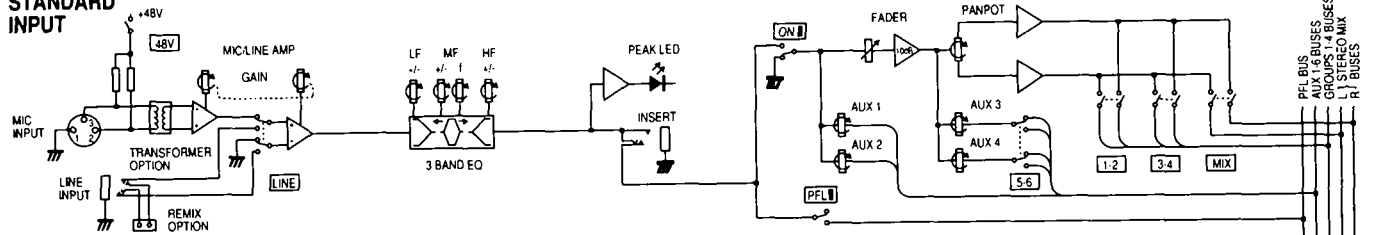

## DELUXE INPUT

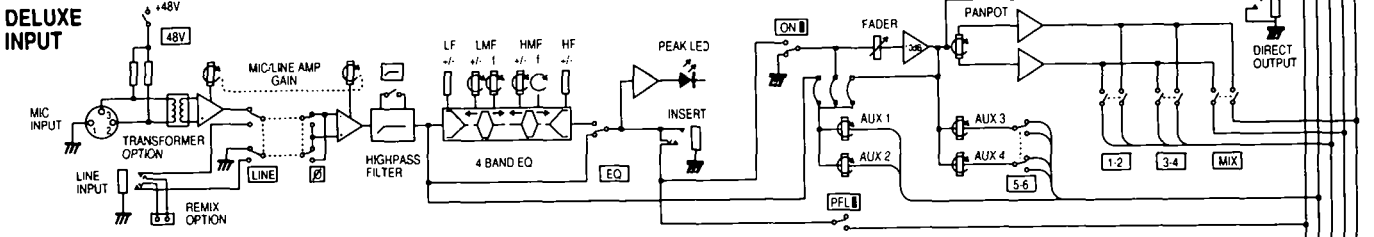

## DUAL LINE INPUT

ONE INPUT SHOWN

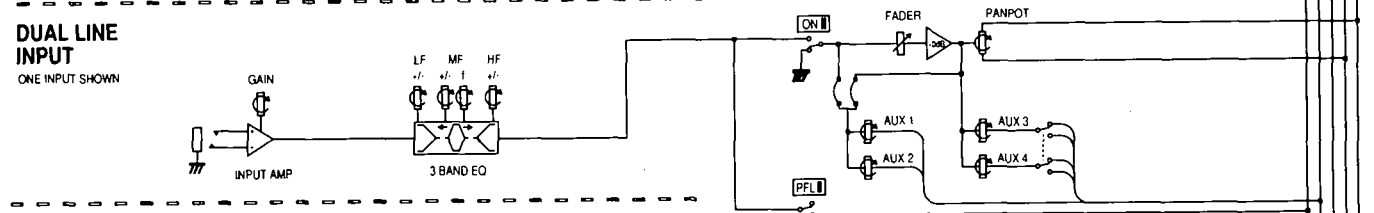

## STEREO LINE INPUT

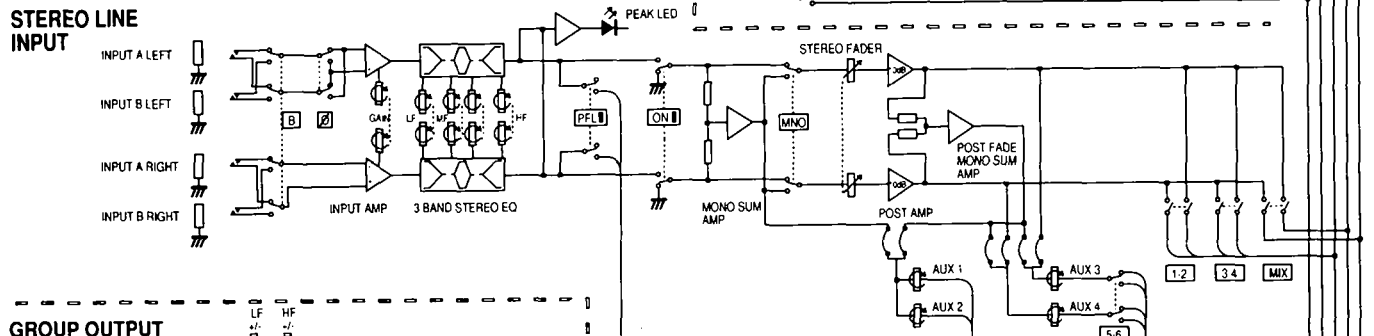

## GROUP OUTPUT

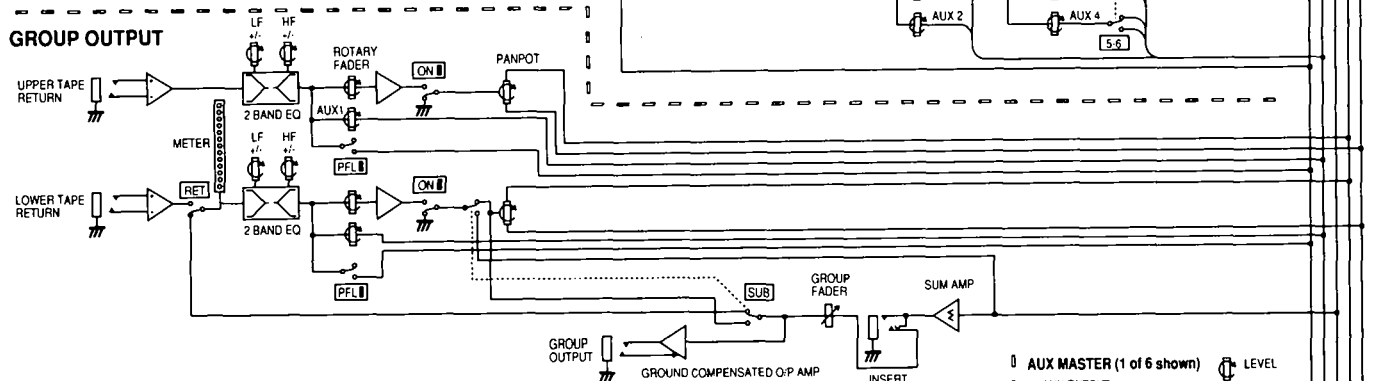

## MASTER

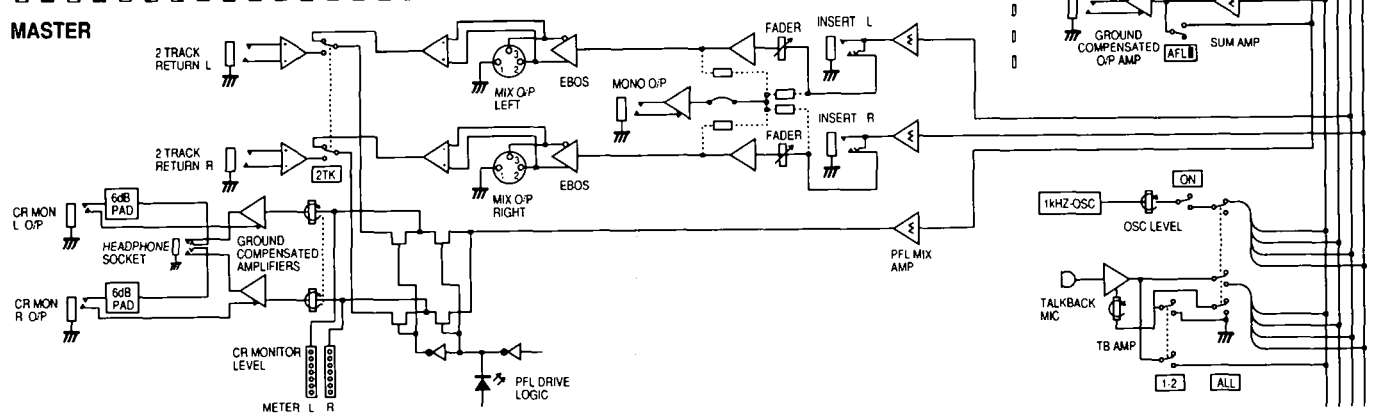

PFL BUS  
 AUX 1-6 BUSES  
 GROUP BUSES  
 STEREO MIX  
 R1 BUSES

# Dimensions

## Delta Desk Outline Dimensions

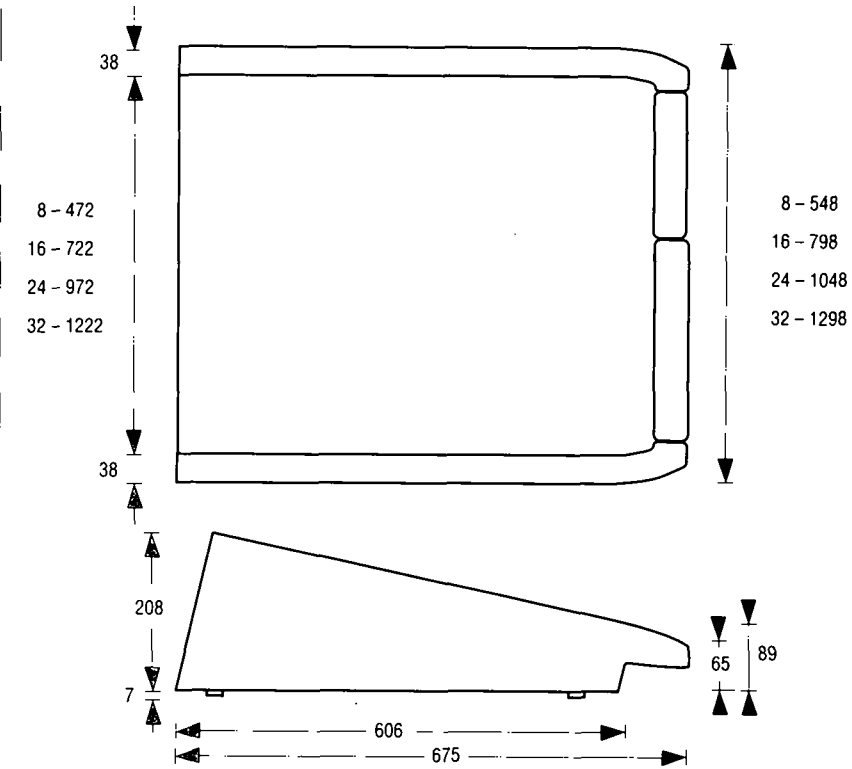

## Delta Rack Outline Dimensions

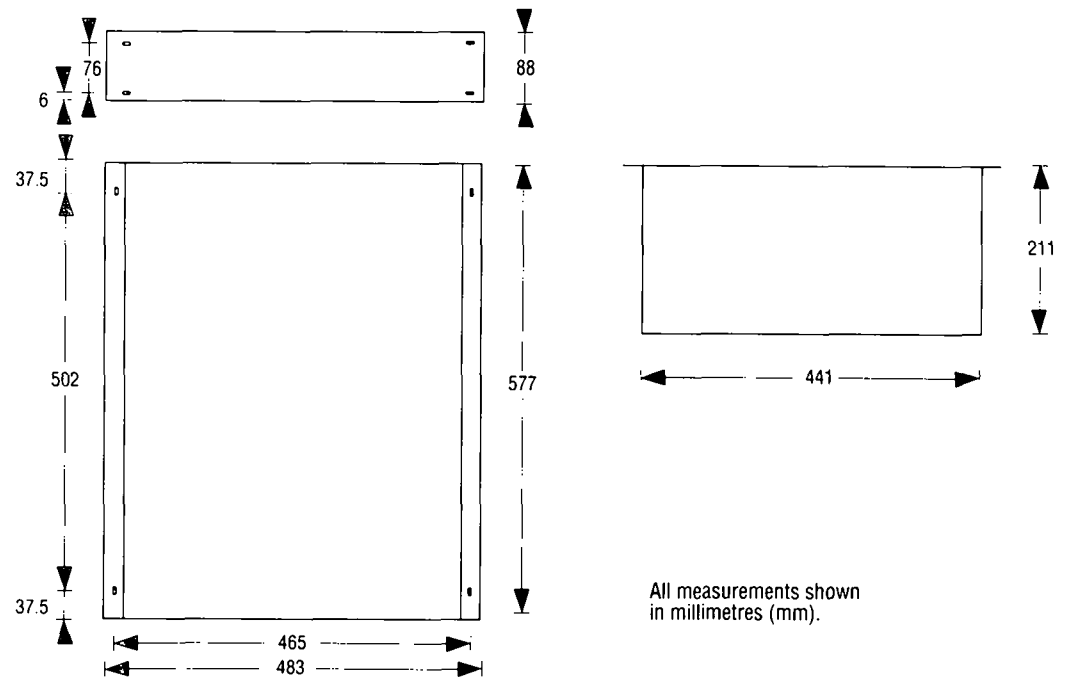

# Configurations

## 8 Input Frame

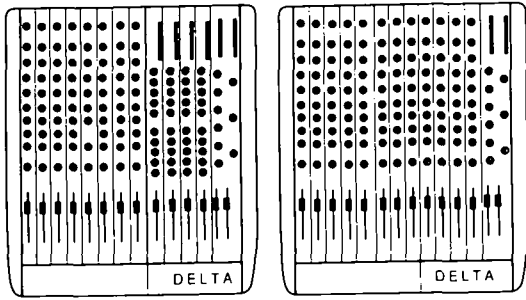

8.4.2

12.2

## 8 Input Rack Frame

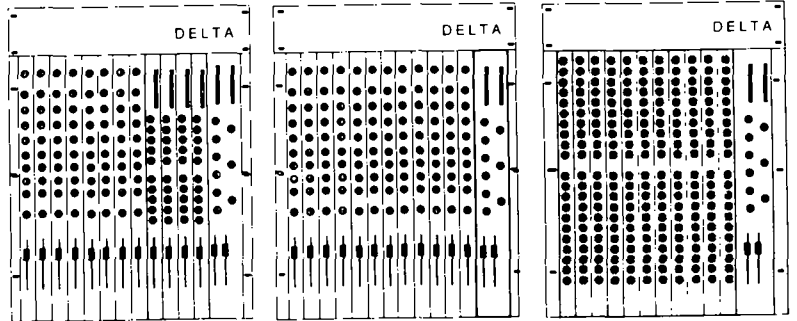

8.4.2 Rack

12.2 Rack

24.2 Rack

## 16 Input Frame

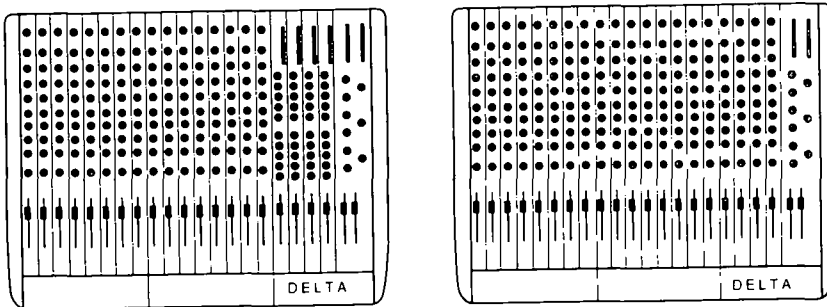

16.4.2

20.2

## 24 Input Frame

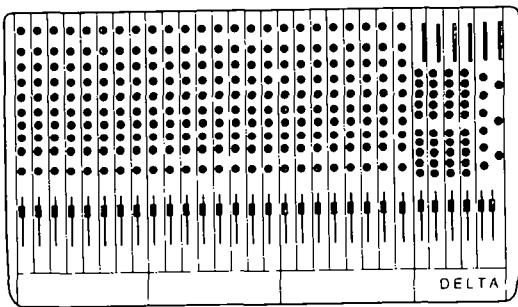

24.4.2

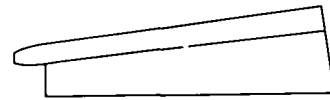

Side profile common to all free standing frame sizes



Side Profile 19" rack frame

## 32 Input Frame

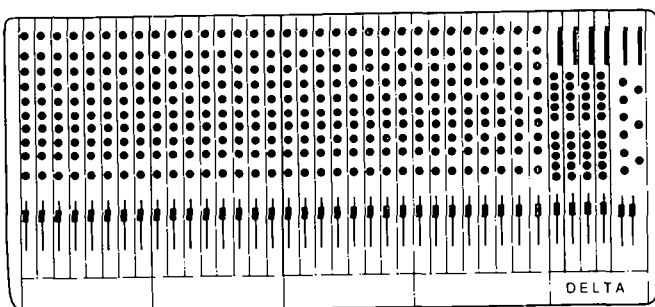

32.4.2

### KEY



Standard Deluxe Stereo Inputs



Dual Line Inputs



Group Outputs



Master

Above only shows samples of most popular options – there are no practical restrictions to potential configurations in any 4 frames, using the individual group modules and separate master module.

# Module descriptions, specifications and operation



# Standard input module

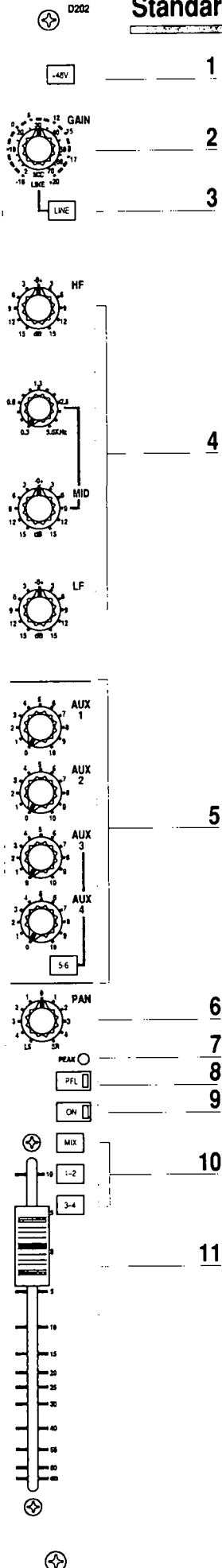

## Channel input

**1** The **+48V** switch switches 48V phantom power to the microphone input, for use with phantom powered condenser microphones and DI boxes.

**2** The **GAIN** control adjusts the sensitivity of both the mic and line inputs. The microphone input is adjustable from -2dBu to -70dBu, and the line from +10dBu to -20dBu.

**3** The **LINE** switch selects the line input to the channel; the default is **MIC**.

## Equaliser

**4** The standard input channel is provided with a 3 band equaliser comprising shelving **HF** and **LF** controls, and a peaking **MID** control, with a frequency control that allows the selection of centre frequencies between 300Hz and 5KHz. Centre detents on the controls indicate the positions for a flat response. Immediately after the EQ section in the signal path is the insert point. This jack on the rear connector panel allows the routing of the channel signal through an external processing device.

## Auxiliaries

**5** Four auxiliary send controls are provided. **AUX 1** and **AUX 2** are fed from a post EQ, pre fader signal, so that the send level is not affected by the channel fader, allowing the easy creation of for example foldback mixes unaffected by changes in the main mix. **AUX 3** and **AUX 4** are fed post EQ, post fader, so their level follows the channel output level set by the fader. Their output can be routed to Aux sends 5 and 6 instead of 3 and 4, by using the **5-6** switch.

## Routing

**6** The **PAN** control determines the relative levels sent to the L/group1/ group3 and R/group2/group4 buses. In the centre, equal levels are sent to both sides (with a 4.5dB level drop relative to fully clockwise or anticlockwise). Rotation fully anticlockwise sends full level to the left/odd buses, cutting the send to the right/even buses; rotation fully clockwise does the opposite.

**10** The routing switches select which buses the post fade, post pan signal is fed to. Each switch enables one Left/Right pair of buses, hence the **1-2** switch sends the signal to groups 1 and 2, the **3-4** switch to groups 3 and 4, and the **MIX** switch to the stereo mix outputs. We recommend that any unused channels are unrouted to maximise the audio performance of the console.

## Frequency Response Curves of the Equaliser

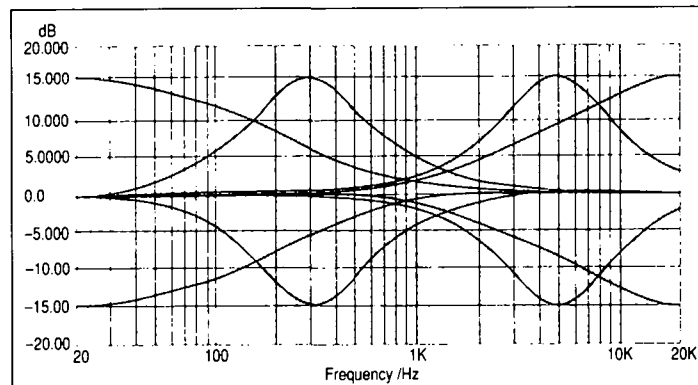



## Channel status

**7** The **PEAK** LED indicator lights when the post EQ signal reaches a level of 4dB below the clipping (severe distortion) point of the channel. If this lights any more than momentarily on transients in the signal, the input **GAIN** should be reduced.

**8** The red illuminated **PFL** switch feeds the post EQ, pre fader signal to the CR monitor outputs (or headphones jack), via the **CR Monitor** level control, replacing the signal currently feeding those outputs. The red PFL LED adjacent to the monitor control on the master module will light to indicate the monitoring status. PFL signals from different sources will be summed.

**9** The **ON** switch enables the post EQ, post insert channel signal path: when 'off', all auxiliary sends and routing outputs are muted. We recommend that you switch all unused channels 'off', to prevent unwanted noise being added to any parts of the mix.

**11** The channel fader is the main level control of the channel, and is a long throw type to enable rapid and accurate control of the channel output level. When mixing, you'll get optimum headroom and signal-to-noise ratios by keeping the fader at about the unity gain (0) mark: avoid running the input **GAIN** too high, and the fader commensurately low, since this gives very little headroom. Similarly, running the input **GAIN** very low, and the fader fully up (10dB of gain) will increase noise levels, and does not give any available increase in gain on the fader should the source signal level drop unexpectedly.

## Rear Connector Panel

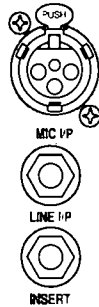

MIC I/P	Pin 1	Screen
	Pin 2	Hot
	Pin 3	Cold
Line I/P	Tip	Hot
	Ring	Cold
	Sleeve	Screen
Insert	Tip	Return
	Ring	Send
	Sleeve	Ground (Screen)

## Specification

**Microphone Input** Electronically balanced, transformer option.

Input impedance	>2Kohms
Maximum input before clipping	+18dBu
Sensitivity range	-2 to -70dBu for +4dBu O/P
CMRR	>80dB at max gain
Equivalent input noise, 200R source	<-127.5dBu at full gain

**Line Input** Electronically balanced.

Input impedance	>10Kohms
Maximum input before clipping	+27dBu
Sensitivity range	-20 to +10dBu for +4dBu O/P
CMRR	>40dB at 1KHz
Equivalent input noise, 40R source	<-93dBu at unity gain

## Equalisation

Boost/cut range	+/-15dB
Break frequencies:	HF 12KHz shelving
	MF 0.3 - 5KHz peaking with Q = 1.5
	LF 60Hz shelving

## General

Insert send nominal level	-2dBu, unbalanced
Insert send maximum output	+21dBu into >5Kohms
Insert return impedance	10Kohms
Mute switch rejection	>90dB at 1KHz >90dB at 10KHz.
Fader rejection	>80dB at 1KHz >75dB at 10KHz.
Panpot rejection	>85dB at 1KHz >80dB at 10KHz.
Routing rejection	>93dB at 1KHz >85dB at 10KHz.
Aux send rejection	>85dB at 1KHz >80dB at 10KHz.
THD	0.008% at 1KHz 0.04% at 10KHz

Refer to appendix for measurement notes and conditions.

# Deluxe input module

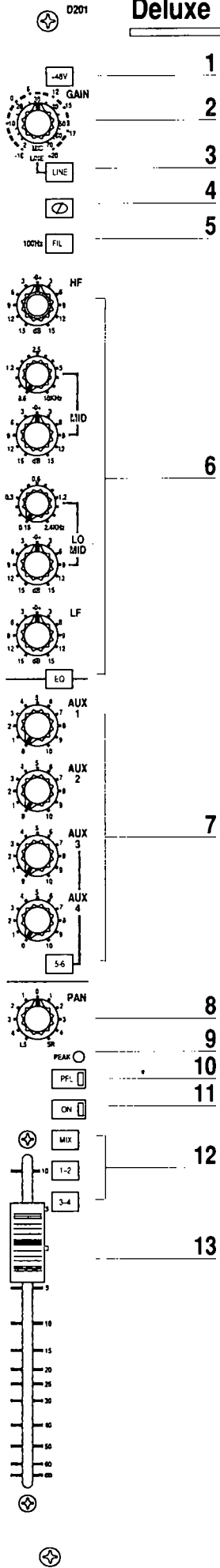

## Channel input

- 1 The **+48V** switch switches 48V phantom power to the microphone input, for use with phantom powered condenser microphones and DI boxes.
- 2 The **GAIN** control adjusts the sensitivity of both the mic and line inputs. The microphone input is adjustable from -2dBu to -70dBu, and the line from +10dBu to -20dBu.
- 3 The **LINE** switch selects the line input to the channel; the default is mic.
- 4 The  switch reverses the phase of the selected input, to compensate for different wiring standards, and conflicting microphone placement.
- 5 The  **highpass filter** switch inserts a 100Hz second order (12dB/octave) highpass filter in the signal path immediately after the input amplifier. This is especially useful for counteracting the proximity effect experienced with directional microphones, and eliminating low frequency 'spill' and interference.

## Equaliser

- 6 The deluxe input channel is provided with a 4 band equaliser comprising shelving **HF** control, a shelving **LF** control with a **VLF** rolloff, and two peaking mid frequency controls: **LO MID** with a frequency control that allows the selection of centre frequencies between 150Hz and 2.5KHz, and **HI MID** with a frequency control giving centre frequencies between 600Hz and 10KHz. Centre detents on the controls indicate the positions for a flat response. The whole EQ section can be switched into the signal path by the **EQ** switch. Immediately after the EQ section in the signal path comes the insert point. This jack on the rear connector panel allows the routing of the channel signal through an external processing device.

## Frequency Response Curves of the Equaliser

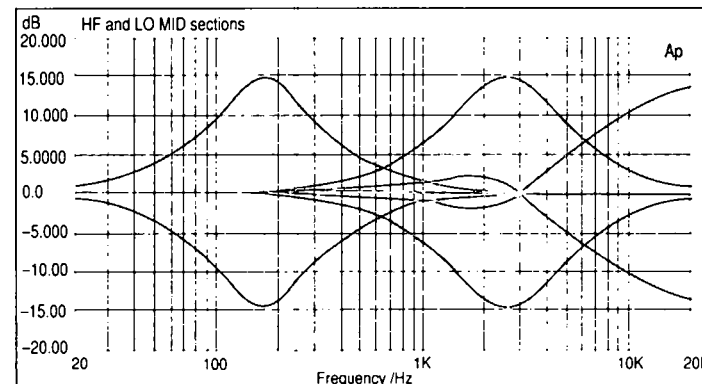
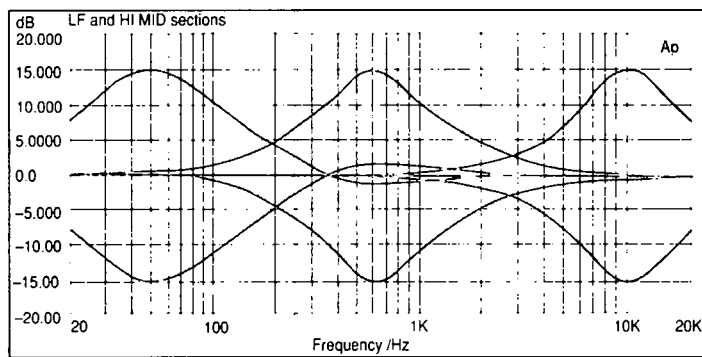

## Auxiliaries

- 7 Four auxiliary send controls are provided: **AUX 1** and **AUX 2** are factory fitted with a link selecting a post EQ, pre fader signal. This can be changed to either a pre EQ, pre fade, or post fade sourcing if desired: see the 200 Delta technical manual for details. **AUX 3** and **AUX 4** are fed post EQ, post fader, hence their level follows the channel output level set by the fader. Their output can be routed to Aux sends 5 and 6 instead of 3 and 4, by using the **5-6** switch.

## Routing

- 8 The **PAN** control determines the relative levels sent to the L/group1/ group3 and R/group2/group4 buses. In the centre, equal levels are sent to both sides (with a 4.5dB level drop relative to fully clockwise or anticlockwise). Rotation fully anticlockwise sends full level to the left/odd buses, cutting the send to the right/even buses, and rotation fully clockwise does the opposite.
- 12 The routing switches select which buses the post fade, post pan signal is fed to. Each switch enables one Left/Right pair of buses, hence the **1-2** switch sends the signal to groups 1 and 2, the **3-4** switch to groups 3 and 4, and the **MIX** switch to the stereo mix outputs. It is recommended that any unused channels are unrouted to maximise the audio performance of the console.

### Channel status

**9** The **PEAK** LED indicator lights when the post EQ signal reaches a level of 4dB below the clipping (severe distortion) point of the channel. If this lights any more than momentarily on transients in the signal, the input **GAIN** should be reduced.

**10** The red illuminated **PFL** switch feeds the post EQ, pre fader signal to the CR monitor outputs (or headphones jack), via the **CR Monitor** level control, replacing the signal currently feeding those outputs. The red PFL LED adjacent to the monitor control on the master module will light to indicate the monitoring status. PFL signals from different sources will be summed.

**11** The **ON** switch enables the post EQ, post insert channel signal path: when off, all auxiliary sends except those selected pre-EQ, and all routing outputs are muted. We recommend that you switch all unused channels 'off', to prevent unwanted noise being added to any parts of the mix.

**13** The channel fader is the main level control of the channel, and is a long throw type to enable rapid and accurate control of the channel output level. When mixing, you'll get optimum headroom and signal-to-noise ratios by keeping the fader at about the unity gain (0) mark: avoid running the input **GAIN** too high, and the fader commensurately low, since this gives very little headroom. Similarly, running the input **GAIN** very low, and the fader fully up (10dB of gain) will increase noise levels, and does not give any available increase in gain on the fader should the source signal level drop unexpectedly.

### Rear Connector Panel

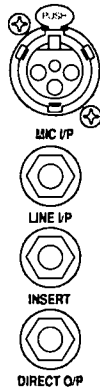

MIC I/P	Pin 1	Screen
	Pin 2	Hot
	Pin 3	Cold
Line I/P	Tip	Hot
	Ring	Cold
	Sleeve	Screen
Insert	Tip	Return
	Ring	Send
	Sleeve	Ground Screen
Direct O/P	Tip	Hot
	Ring	Signal (Ground)
	Sleeve	Ground (Screen)

### Specification

**Microphone Input** Electronically balanced, transformer option.

Input impedance	>2Kohms
Maximum input before clipping	+18dBu
Sensitivity range	-20 to -70dBu for +4dBu O/P
CMRR	>80dB at max gain
Equivalent input noise, 200R source	<-127.5dBu at full gain

**Line Input** Electronically balanced.

Input impedance	>10Kohms
Maximum input before clipping	+27dBu
Sensitivity range	-20 to +10dBu for +4dBu O/P
CMRR	>40dB at 1KHz
Equivalent input noise, 40R source	<-93dBu at unity gain

### Equalisation

Boost/cut range	+/-15dB
Break frequencies :	HF 12KHz shelving HMF 0.6 - 10KHz peaking with Q = 1.5 LMF 0.15 - 2.5KHz peaking with Q = 1.5 LF 60Hz shelf with VLF rolloff at 30 Hz
Highpass filter	-3dB at 100Hz, 2nd order

### General

Insert send nominal level	-2dBu, unbalanced
Insert send maximum output	+21dBu into >5Kohms
Insert return impedance	10Kohms
Direct output nominal level	-2dBu, unbalanced
Direct output maximum output	+21dBu into >5Kohms
Mute switch rejection	>90dB at 1KHz >90dB at 10KHz.
Fader rejection	>80dB at 1KHz >75dB at 10KHz.
Panpot rejection	>85dB at 1KHz >80dB at 10KHz.
Routing rejection	>93dB at 1KHz >85dB at 10KHz.
Aux send rejection	>85dB at 1KHz >80dB at 10KHz.
THD	0.005% at 1KHz 0.015% at 10KHz

Refer to appendix for measurement notes and conditions.

# Dual line input module

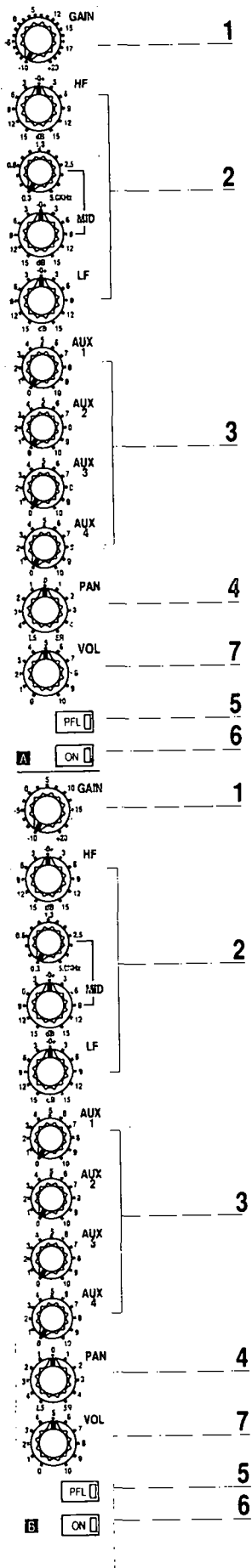

The dual line input module comprises two identical channels, each outputting to the stereo mix bus.

## Channel input

**1** The **GAIN** control adjusts the sensitivity of the line input from +10dBu to -20dBu.

## Auxiliaries

**3** Four auxiliary send controls are provided: **AUX 1** and **AUX 2** are factory linked to be fed from a post EQ, pre fader signal, which can be changed to a post EQ, post fader signal if desired: see the 200Delta technical manual for details. **AUX 3** and **AUX 4** are fed post EQ, post fader, so their levels follow the channel output level set by the fader. Their output is normally routed to Aux sends 3 and 4, but can be changed to Aux sends 5 and 6 by internal switches: again see the technical manual for details.

## Equaliser

**2** Each dual line input channel is provided with a 3 band equaliser comprising shelving **HF** and **LF** controls, and a peaking **MID** control, with a frequency control that allows the selection of centre frequencies between 300Hz and 5KHz. Centre detents on the controls indicate the positions for a flat response. (EQ Plot diagram)

## Routing

**4** The **PAN** control determines the relative levels sent to the L and R outputs. In the centre, equal levels are sent to both sides (with a 4.5 dB level drop relative to fully clockwise or anticlockwise). Rotation fully anticlockwise sends full level to the left/odd buses, cutting the send to the right/even buses; rotation fully clockwise does the opposite.

Frequency Response Curves of the Equaliser

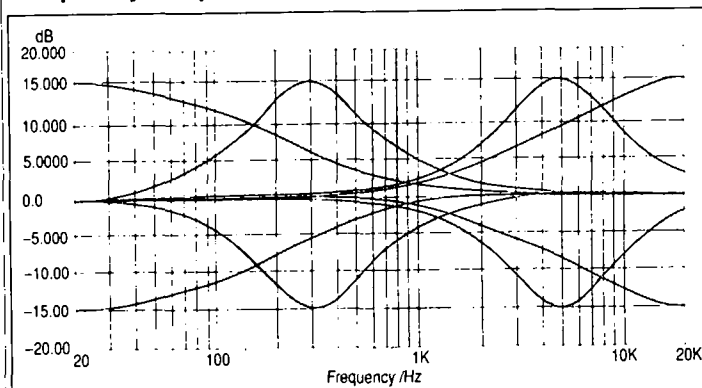

## Channel status

**5** The red illuminated **PFL** switch feeds the post EQ, pre fader signal to the CR monitor outputs (or headphones jack), via the **CR Monitor** level control, replacing the signal currently feeding those outputs. The red PFL LED adjacent to the monitor control on the master module will light to indicate the monitoring status. PFL signals from different sources will be summed.

**6** The **ON** switch enables the post EQ signal path: when 'off', all auxiliary sends and L/R outputs are muted. We recommend that you switch all unused channels 'off', to prevent unwanted noise being added to any parts of the mix.

**7** The rotary channel fader (**VOL**) is the main level control of the channel. When mixing, you'll get optimum headroom and signal to noise ratios by keeping the fader at about the unity gain (7) mark: avoid running the input **GAIN** too high, and the fader commensurately low, since this gives very little headroom. Similarly, running the input **GAIN** very low, and the fader fully up (10dB of gain) will increase noise levels, and does not give any available increase in gain on the fader should the source signal level drop unexpectedly.

## Rear Connector Panel



I/P A & B	Tip	Hot
	Ring	Cold
	Sleeve	Ground (Screen)

## Specification

**Line Input** Electronically balanced

Input impedance	>10Kohms
Maximum input before clipping	+27dBu
Sensitivity range	-20 to +10dBu for +4 O/P
CMRR	>40dB at 1KHz
Equivalent input noise	-20 to +10dBu for + 4dBu output.

## Equalisation

Boost/cut range	+/-15dB
Break frequencies:	HF 12KHz shelving MF 0.3 - 5KHz peaking with Q = 1.5 LF 60Hz shelving

## General

Mute switch rejection	>90dB at 1KHz	>85dB at 10KHz.
Fader rejection	>85dB at 1KHz	>80dB at 10KHz.
Panpot rejection	>60dB at 1KHz	>80dB at 10KHz.
Aux send rejection	>80dB at 1KHz	>75dB at 10KHz.
THD	0.005% at 1KHz	
	0.03% at 10KHz	

Refer to appendix for measurement notes and conditions.

# Stereo input module

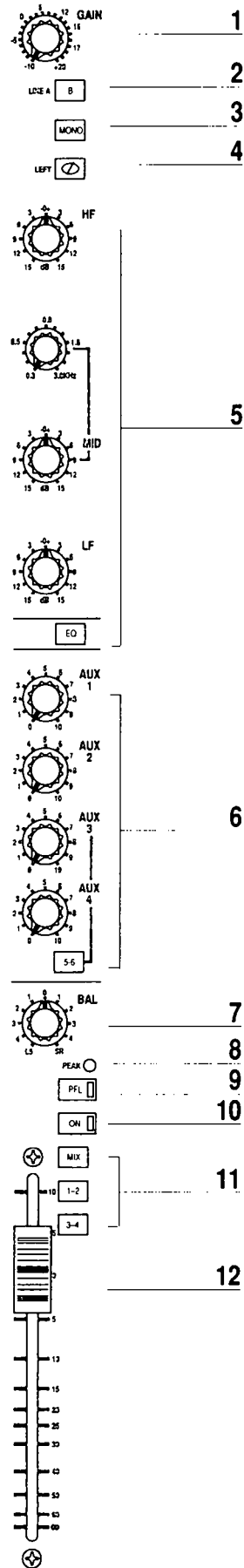

## Channel input

**1** The **GAIN** control adjusts the sensitivity of the line inputs of both channels from +10dBu to -20dBu.

**2** The **B** switch selects the alternative B line inputs. These may be fitted with an RIAA preamplifier, to enable the direct connection of magnetic phono cartridges to the mixing desk: see appendix for ordering details.

**3** The **MONO** switch sums Left + Right inputs and feeds the channel with the resultant mono signal. The **BAL** control will then act as a pan control.

**4** The **LEFT** switch reverses the phase of the left channel, for situations where a phasing error has occurred.

## Equaliser

**5** The stereo line input channel is provided with a 3 band equaliser comprising shelving **HF** and **LF** controls, and a peaking **MID** control, with a frequency control that allows the selection of centre frequencies between 300Hz and 3KHz. Centre detents on the controls indicate the positions for a flat response.

## Auxiliaries

**6** Four auxiliary send controls are provided:

**AUX 1** and **AUX 2** are factory linked to be fed from a post EQ, prefade mono sum signal, which can be changed to a post EQ, post fade mono signal if desired: see the 200 Delta technical manual for details. **AUX 3** and **AUX 4** are factory linked to be fed a post EQ, post fade mono sum, but this can be changed so that the left channel feeds Aux 3 (Aux 5), and the right channel feeds aux 4 (Aux 6). Their output is normally routed to Aux sends 3 and 4, but can be changed to Aux sends 5 and 6 by the **5-6** switch.

## Routing

**7** The **BAL** control determines the relative level of the L and R channels. In the centre, the equal levels are sent to both sides (with a 4.5dB level drop relative to fully clockwise or anticlockwise). Rotation fully anticlockwise sends full level to the left/odd buses, cutting the send to the right/even buses, and rotation fully clockwise does the opposite.

**11** The routing switches select which buses the post fade, post pan signal is fed to. Each switch enables one Left/Right pair of buses, hence the **1-2** switch sends the signal to groups 1 and 2, the **3-4** switch to groups 3 and 4, and the **MIX** switch to the stereo mix outputs. It is recommended that any unused channels are unrouted to maximise the audio performance of the console.

## Frequency Response Curves of the Equaliser

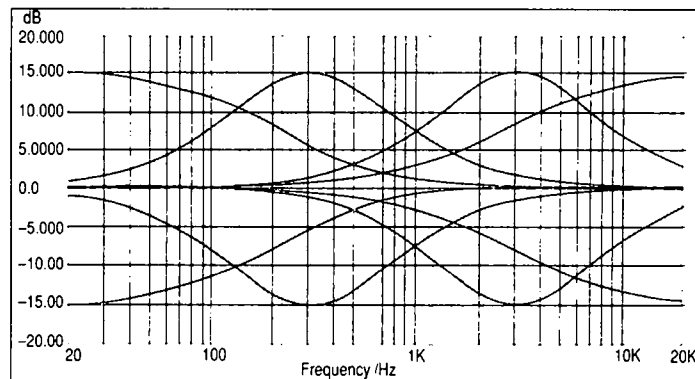

## Channel status

**8** The **PEAK** LED indicator lights when the post EQ signal reaches a level of 4dB below the clipping (severe distortion) point of the channel. If this lights any more than momentarily on transients in the signal, the input **GAIN** should be reduced.

**9** The red illuminated **PFL** switch feeds the post EQ, pre fade mono sum to the CR monitor outputs (or headphones jack), via the **CR Monitor** level control, replacing the signal currently feeding those outputs. The red PFL LED adjacent to the monitor control on the master module will light to indicate the monitoring status. PFL signals from different sources will be summed.

**10** The **ON** switch enables the post EQ signal path: when off, all auxiliary sends and L/R outputs are muted. We recommend that you switch all unused channels 'off', to prevent unwanted noise being added to any parts of the mix.

**12** The stereo 100mm fader is the main level control of the channel, giving rapid control of the levels of both channels simultaneously. When mixing, you'll get optimum headroom and signal-to-noise ratios by keeping the fader at about the unity gain (0) mark: avoid running the input **GAIN** too high, and the fader commensurately low, since this gives very little headroom. Similarly, running the input **GAIN** very low, and the fader fully up (10dB of gain) will increase noise levels, and does not give any available increase in gain on the fader should the source signal level drop unexpectedly.

## Rear Connector Panel



All Inputs	Tip	Hot
	Ring	Cold
	Sleeve	Ground
		(Screen)

## Specification

**Line Inputs** Electronically balanced.

Input impedance	>10Kohms
Maximum input before clipping	+27dBu
Sensitivity range	-20 to +10dBu for +4 O/P
CMRR	>40dB at 1KHz
Equivalent input noise, 40R source	<-93dBu at unity gain

### Equalisation

Boost/cut range	+/-15dB
Break frequencies:	HF 12KHz shelving
	MF 0.3 - 3KHz peaking with Q = 1.0 min
	LF 60Hz shelving

### RIAA option

Input impedance	47Kohms//220pF
Signal-to-noise ratio	86dB below 5mV I/P
Sensitivity	5mV at 1KHz at max gain
Headroom	+21dB
Crosstalk	<-40dB at 1KHz
Response accuracy	+/-0.5dB, with IEC amendment to LF response, and subsonic filter

### General

Mute rejection	>90db at 1KHz	>85db at 10KHz.
Fader rejection	>80dB at 1KHz	>80dB at 10KHz.
Balance pot rejection	>85dB at 1KHz	>80dB at 10KHz.
Routing rejection	>90dB at 1KHz	>85dB at 10KHz.
L/R crosstalk	<-75dB at 1KHz	<-65dB at 10KHz.
THD	0.004% at 1KHz	0.015% at 10KHz

Refer to appendix for measurement notes and conditions

# Group output module

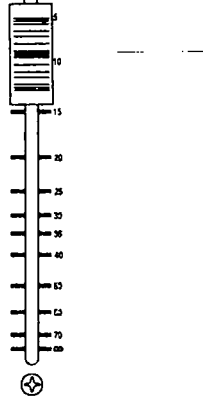
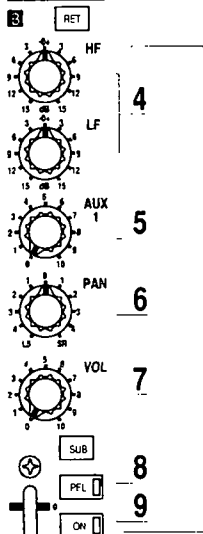
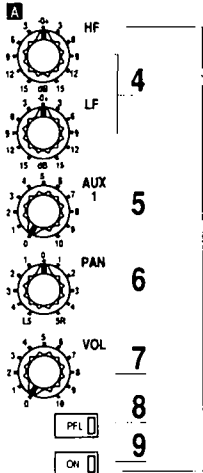
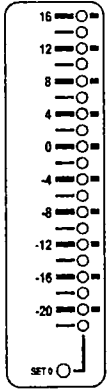

## Return

**1** Upper return: this input feeds an external signal onto the stereo mix bus.

**2** Lower return: this input is fed from the group output or if the **RET** switch is pressed, an external return signal. It feeds the stereo mix bus. The LED bargraph meter (11) follows the lower return source selection, and is link selectable for peak or average ballistics: see the 200 Delta technical manual for details. The **SUB** switch converts the group into a sub-group, feeding the group mix signal directly to the stereo mix via the return **PAN** control. If the **SUB** and **RET** switches are both pressed, then the return signal is routed to the group mix, which is in turn routed to the stereo mix: thus the return signal is under control of the group fader.

## Equaliser

**4** Each return is provided with a 2-band equalizer, the centre detented controls giving shelving characteristics at 8KHz (**HF**), and 60Hz (**LF**).

## Auxiliary

**5** The **AUX 1** control gives a pre fade feed to Auxiliary send 1, enabling the return signals to be sent to a foldback mix.

## Routing

**6** The **PAN** control sets the position of the return signal across the stereo mix.

**NORMAL OPERATION**

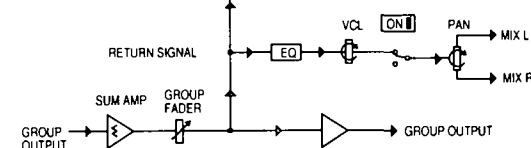

**SUB SELECTED**

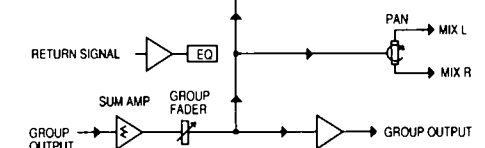

**RET SELECTED**

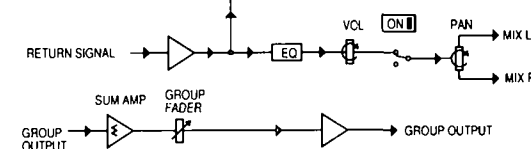

**SUB & RET SELECTED**

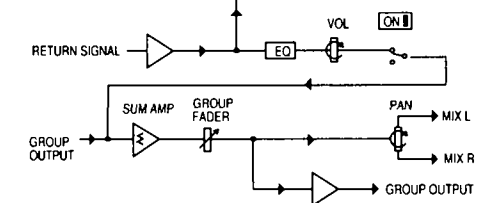

## Frequency Response Curves of the Equaliser

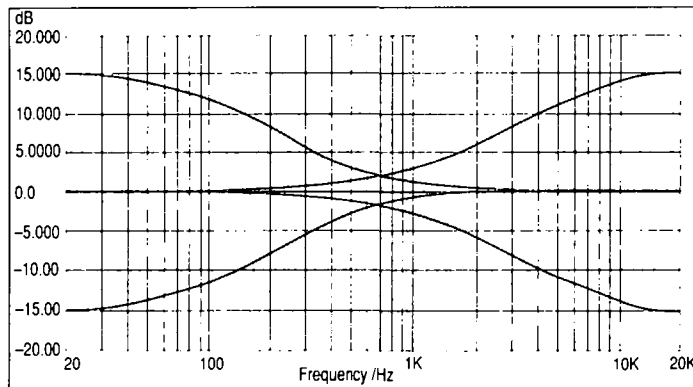



## Channel status

**3** Group fader: this 100mm fader controls the level of the group mix & Group output. The nominal output level may be set at either +4dBu or -10dBV by an internal switch: see the 200 Delta Technical manual for details.

**7** The **VOL** control determines the level of the return signal.

**8** The red illuminated **PFL** switch feeds the post EQ, pre fader signal to the CR monitor outputs (or headphones jack), via the **CR Monitor** level control, replacing the signal currently feeding those outputs. The red PFL LED adjacent to the monitor control on the master module will light to indicate the monitoring status. PFL signals from different sources will be summed.

**9** The **ON** switch enables the return signal. If the return is not being used, it should be switched 'off', to obtain the best noise performance from the console.

## Rear Connector Panel

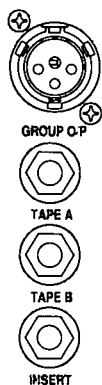

**10**

**10** An insert point is provided in the signal path of the group so that an external processing device can be inserted.

Group O/P	Pin 1	Ground (Screen)
	Pin 2	Hot
	Pin 3	Ground sense (cold)

Tape Returns	Tip	Hot
	Ring	Cold
	Sleeve	Ground (Screen)

Insert	Tip	Return
	Ring	Send
	Sleeve	Ground (Screen)

## Specification

**Group Output** Unbalanced, ground compensated.

Insert send nominal level	-8dBu
Insert send maximum output	+21dBu into >1Kohms
Insert return impedance	10Kohms
Nominal output level	+4dBu/-10dBV, selectable
Maximum output level	+21dBu into >600ohms
Output impedance	75ohms
Group - group crosstalk	<-80dB at 1KHz
Fader rejection	>80dB at 1KHz
Bus residual noise	<-93dBu
Mix bus noise	<-80dBu
Typical mix noise	<-75dBu
THD	0.003% at 1KHz 0.007% at 10KHz

**Tape/effects returns** Electronically balanced.

Input impedance	>10Kohms
Nominal input level	+4dBu/-10dBV, selectable
Maximum input level	+21 above nominal
Equalisation	15 dB boost/cut range HF 8KHz shelving LF 60Hz shelving

**Meter** 20 segment LED bargraph.

Response:	Peak or average reading
Rise time to -1dB:	150msec (average) 4msec (Peak)
Decay time to -20dB:	250msec (average) 1.2 sec (Peak)
Accuracy relative to 0dB	+/-1dB.
Calibration range	0dB= -2dBu....+20dBu (output nom. level = +4)

Refer to appendix for measurement notes and conditions

# Master output module

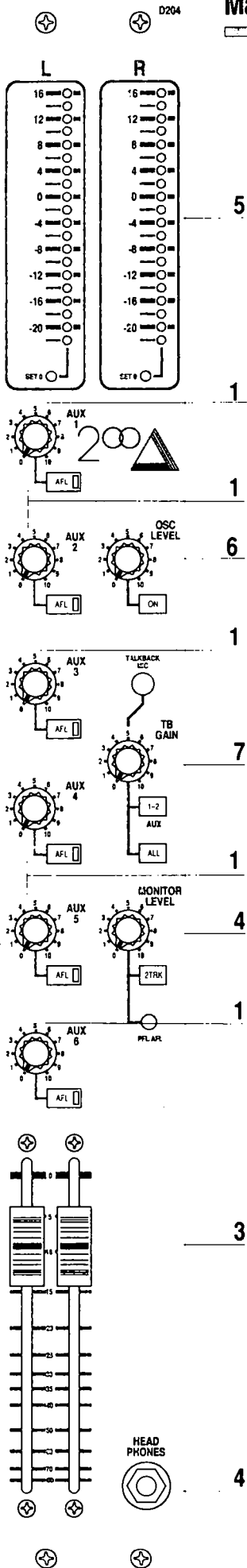

## Auxiliaries

**1** The auxiliary send master level controls set the output level of the auxiliary send mixes: the output level can be conveniently monitored using the aux send **AFL** switches. Optimum noise performance will be obtained with the send controls on the input channels turned up far enough to give a **peak** output level (metered using the aux send **AFL** switch) of +16 with the output level control at unity gain (7 on the scale). The output level should then be turned down to suit the input level of the device the send is driving.

## Master Outputs

**2** Insert points are provided in the stereo mix signal path to enable the insertion of external processing devices in the signal path.

**3** The master output faders control the level of the stereo mix output. In order to preserve headroom, they should normally be run in the top 10dB of their range. If the stereo output is feeding a device which requires a lower input level (e.g. a domestic tape recorder), the reference level of the output and 2-track return level should be changed using the internal switch: see the 200 Delta technical manual.

## Output meters

**5** The stereo output meters automatically follow the monitor selection of mix/2 track/PFL, though the meter reading is independent of the **MONITOR LEVEL**. The meter reading is relative to the operating level selected (see **3** above).

## Monitoring

**4** Provision is made to monitor the stereo mix output, the PFL signal and the 2 track return (see **Ancillary Connector Panel**). The **CR MON** jacks on this panel are available to drive on external power amplifier/loudspeakers, alternatively stereo headphones can be plugged into the front panel jack: this will mute the **CR MON** outputs. The level is set by the **MONITOR LEVEL** control. Selection of the two **TRK** switch routes the 2 track tape return inputs to the monitors. Selecting a **PFL** switch on any input will automatically switch the monitoring to the PFL signal, overriding the Mix/2 track selection.

**Oscillator**

**6** A 1KHz oscillator is provided, which feeds a sine wave output of up to +16dBu to all groups, the stereo mix and aux buses, at a level set by the **OSC LEVEL** control. The oscillator is enabled by the **ON** switch, and is overridden by the selection of the talkback switch.

**Talkback**

**7** Talkback can be routed to either aux send 1 and 2 (**1-2** switch), or to all buses (**ALL** switch). An integral mic is provided, flush mounted behind the front panel, with an associated gain control **TB GAIN**. In order to avoid acoustic feedback, the CR monitor outputs are attenuated ("Dimmed") by approximately 20dB when talkback to Aux 1-2 is selected, and muted when talkback to **ALL** is selected.

**Rear Connector Panel**

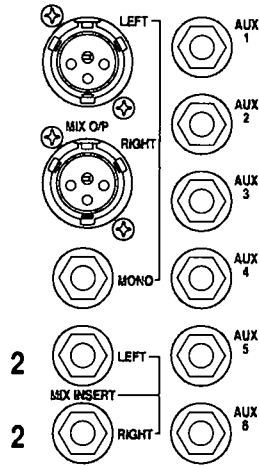

**Master Fascia Rear Connections**

Mix O/P's	Pin 1	Ground (Screen)
	Pin 2	Hot
	Pin 3	Cold
Mon O/P	Tip	Hot
Aux O/P's	Ring	Ground Sense (Cold)
	Sleeve	Ground (Screen)
Mix Inserts	Tip	Return
	Ring	Send
	Sleeve	Ground (Screen)

4 4

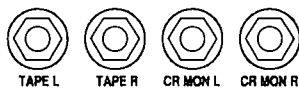

**Ancillary Connector Panel**

CR MON O/P's	Tip	Hot
	Ring	Ground sense (Cold)
	Sleeve	Ground (Screen)
2 TRK TAPE Returns	Tip	Hot
	Ring	Cold
	Sleeve	Ground (Screen)

**Specification**

**Auxiliary Send Outputs** Unbalanced, ground compensated.

Nominal level	+4dBu
Maximum output level	+21dBu into >600R
Output impedance	75ohms
Master gain control range	+10...-85 dB
Mix bus noise	<-80dBu
Aux - Aux crosstalk (all but one fed signal)	<-80dBu at 1KHz
THD	0.003% at 1KHz 0.006% at 10KHz

**Mix L&R Outputs** Electronically balanced.

Insert send nominal level (unbal)	-8dBu
Insert send maximum output	+21dBu into >1Kohms
Insert return impedance	10Kohms
Master fader rejection	>80dB at 1KHz
Stereo mix output Nom. level	+4dBu/-10dBV selectable
Stereo mix maximum output	+27dBu into >600ohms
Output impedance	75ohms
CMRR	>40dB at 1KHz
L/R crosstalk	<-80dB at 1KHz
THD	0.003% at 1KHz 0.006% at 10KHz
Mono output level (unbal)	+1dBu
Mono maximum output level	+21dBu into >600ohms

**Monitor outputs and switching**

CR Mon nominal output level	+4dBu
Maximum output level	+15dBu into >5Kohms
Output impedance	250ohms
Headphone nominal output level	+10dBu
Headphone output maximum level	+20dBu into 600ohms +15dBu into 50ohms +4 dBu into 8ohms
2-track return nominal level	+4dBu/-10dBV switchable
2-track return maximum level	+25dBu
2-track return to mix crosstalk	<-85dB at 1KHz

**Oscillator**

Max level at group/mix O/P	+16dBu
Frequency	1KHz +/-10%
Distortion	<1% THD

**Meter** 20 segment LED bargraph.

Response:	Peak or average reading
Rise time to -1dB:	150msec (average) 4msec (Peak)
Decay time to -20 dB:	250msec (average) 1.2 sec (Peak)
Accuracy relative to 0dB	+/-1dB
Calibration range	0dB= -2dBu...+20dBu (output nom. level = +4)

## Delta Specifications

### Typical Performance Figures Measured On 16 Channel Console

#### TOTAL HARMONIC DISTORTION

*Measured @ +20 dBu, 10 Hz to 80KHz Bandwidth, Unweighted*

Group Output	1 kHz: 0.003%	10 kHz: 0.007%
Mix Output	1 kHz: 0.003%	10 kHz: 0.006%
Aux Output	1 kHz: 0.003%	10 kHz: 0.006%
Standard Input to Mix Output	1 kHz: 0.008%	10 kHz: 0.04%
Deluxe Input to Line Output	1 kHz: 0.005%	10 kHz: 0.015%
Oscillator to Group Output @ +16 dBu		1 kHz: <1%

#### CROSSTALK

*Measured @ 1 kHz.*

Channel Muting	>90dB
Maximum Fader Attenuation	>80dB
Panpot Isolation (Active Pan)	>85dB
Routing (Channel to Groups)	>90dB
Maximum Aux Send Attenuation	>80dB
Mic, Input @ Max Gain, CMRR	>80dB
Line Input @ Unity Gain, CMRR	>40dB

#### NOISE

*Measured 22 Hz to 22 kHz Bandwidth, Unweighted*

Mix Input @ Max Gain, EIN with 200 $\Omega$ Source	-127.5 dBu
Line Input @ Unity Gain, EIN with 40 $\Omega$ Source	-93 dBu
Mix Bus Noise (M Channels Routed, Faders Down)	-80 dBu
Typical Mix Output Noise (16 Channels Routed)	-75 dBu
Aux Bus Noise (16 Inputs)	-78 dBu

#### FREQUENCY RESPONSE

Mic or Line Input to Any Output	20 Hz to 20 kHz	+0, -0.5 dB
---------------------------------	-----------------	-------------

#### INPUT & OUTPUT LEVELS

Mic Input Max Level	+18 dBu
Line Input Max Level	+27 dBu
Insert Send Max Level into 5K $\Omega$	+21 dBu

#### INPUT & OUTPUT LEVELS *continued*

Insert Send Nominal Level	-2 dBu
Direct Output Max Level into 5K $\Omega$	+21 dBu
Direct Output Nominal Level	-2 dBu
Group Output Max Level into 600 $\Omega$	+21 dBu
Group Insert Nominal Level	-8 dBu
Group Output Nominal Levels	-10 dBV or +4 dBu
Aux Output Max Level into 600 $\Omega$	+21 dBu
Aux Output Nominal Level	+4 dBu
Mix Output Max Level into 600 $\Omega$	+27 dBu
Mix Insert Nominal Level	-8 dBu
Mix Output Nominal Levels	-10 dBV or +4 dBu
Internal Operating Levels	-2 dBu
Oscillator Max Level @ Group Output	+16 dBu
Headphones Output Max Level into 600 $\Omega$	+20 dBu

#### INPUT & OUTPUT IMPEDANCES

Mic Inputs	
Electronically Balanced (Transformer Option)	>2 k $\Omega$
Line Inputs Electronically Balanced	>10 k $\Omega$
R.I.A.A. Inputs	220 pF, 47 k $\Omega$
Insert Sends	75 $\Omega$
Insert Returns	10 k $\Omega$
Outputs	75 $\Omega$

#### METERING

20 Segment LED Bargraph	
Selectable, Peak or Average Reading	
Calibration Range	'0' dB = -2 dBu to +20 dBu
Accuracy Relative to '0' dB	+/- 1dB

For full details of measurement conditions and further specifications, please contact your local Soundcraft dealer.

1. **Soundcraft** means Soundcraft Electronics Ltd.  
**End User** means the person who first puts the equipment into regular operation.  
**Dealer** means the person other than Soundcraft (if any) from whom the End User purchased the Equipment, provided such a person is authorised for this purpose by Soundcraft or its accredited Distributor.  
**Equipment** means the equipment supplied with this manual.
2. If within the period of twelve months from the date of delivery of the Equipment to the End User it shall prove defective by reason only of faulty materials and/or workmanship (but not faulty design) to such an extent that the effectiveness and/or usability thereof is materially affected the Equipment or the defective component should be returned to the Dealer or to Soundcraft and subject to the following conditions the Dealer or Soundcraft will repair or at its option replace the defective components. Any components replaced will become the property of Soundcraft.
3. Any Equipment or component returned will be at the risk of the End User whilst in transit (both to and from the Dealer or Soundcraft) and postage must be prepaid.
4. This warranty shall only be available if:
  - a) the Equipment has been properly installed in accordance with instructions contained in Soundcraft's manual; and
  - b) the End User has notified Soundcraft or the Dealer within 14 days of the defect appearing; and
  - c) no persons other than authorised representatives of Soundcraft or the Dealer have effected any replacement of parts maintenance adjustments or repairs to the Equipment; and
  - d) the End User has used the Equipment only for such purposes as Soundcraft recommends, with only such operating supplies as meet Soundcraft's specifications and otherwise in all respects in accordance with Soundcraft's recommendations.
5. Defects arising as a result of the following are not covered by this Warranty: faulty or negligent handling, chemical or electro-chemical or electrical influences, accidental damage, Acts of God, neglect, deficiency in electrical power, air-conditioning or humidity control.
6. The benefit of this Warranty may not be assigned by the End User.
7. End Users who are consumers should note their rights under this Warranty are in addition to and do not affect any other rights to which they may be entitled against the seller of the Equipment.

## Glossary

<b>auxiliary send</b>	an output from the console comprising a mix of signals from channels and groups derived independently of the main stereo/group mixes. Typically the feeds to the mix are implemented on rotary level controls.
<b>balance</b>	the relative levels of the left and right channels of a stereo signal.
<b>clipping</b>	the onset of severe distortion in the signal path, usually caused by the peak signal voltage being limited by the circuit's power supply voltage.
<b>CR (control room) monitors</b>	loudspeakers used by the operator (engineer) in the control room to listen to the mix.
<b>dB (decibel)</b>	a ratio of two voltages or signal levels, expressed by the equation $\text{dB} = 20\text{Log}_{10} (V1/V2)$ . Adding the suffix 'u' denotes the ratio is relative to 0.775V RMS.
<b>DI (direct injection)</b>	the practice of connecting an electric musical instrument directly to the input of the mixing console, rather than to an amplifier and loudspeaker which is covered by a microphone feeding the console.
<b>equaliser</b>	a device that allows the boosting or cutting of selected bands of frequencies in the signal path.
<b>foldback</b>	a feed sent back to the artistes via loudspeakers or headphones to enable them to monitor the sounds they are producing.
<b>frequency response</b>	the variation in gain of a device with frequency.
<b>(sub) group</b>	an output into which a group of signals can be mixed.
<b>headroom</b>	the available signal range above the nominal level before clipping occurs.
<b>highpass filter</b>	a filter that rejects low frequencies.
<b>line level signals</b>	signals at a nominal level of $-10$ to $+6$ dBu, coming from a low impedance source.
<b>pan (pot)</b>	abbreviation of 'panorama': controls levels sent to left and right outputs.
<b>peaking</b>	an equaliser response curve affecting only a band of frequencies i.e. based on a bandpass response.
<b>PFL (pre fade listen)</b>	a function that allows the operator to monitor the pre fade signal in a channel independently of the main mix.
<b>rolloff</b>	a fall in gain at the extremes of the frequency response.

**Glossary**

<b>shelving</b>	an equaliser response affecting all frequencies above or below the break frequency i.e. a highpass or lowpass derived response.
<b>spill</b>	<i>acoustic interference from other sources.</i>
<b>talkback</b>	the operator speaking to the artistes or to tape via the auxiliary or group outputs.
<b>transient</b>	a momentary rise in the signal level.

